

# MasterSeal 910

Formerly: Masterflex 610

## Hydroswelling waterbar for construction joints.

### DESCRIPTION

MasterSeal 910 is a hydroswelling waterbar, ready for installation, to waterproof joints in concrete structures. The product is based on a special polymer technology that acts by swelling on exposure to water, to form a seal and render the joints leak-proof.

### FIELDS OF APPLICATION

MasterSeal 910 hydroswelling waterbar is suitable for all construction joints subject to hydrostatic pressure, on one or both sides.

Application areas include joints between:

- Abutments of concrete and rock, masonry, etc.
- Rafts and walls in tunnels and basements.
- Steel and concrete pipes, H-king, precast elements, etc.

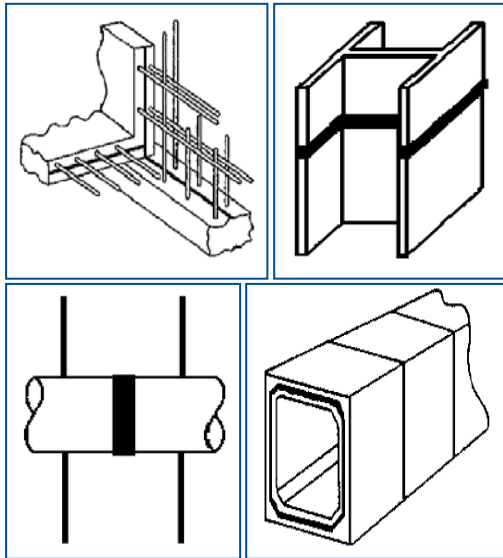

### FEATURES AND BENEFITS

MasterSeal 910 offers the following benefits:

- Swells in contact with water by up to 200% - prevents water ingress even when the joint width varies.

- Water molecules held by molecular attraction – captured water does not get transported through capillaries.
- The volume expansion effect is equally effective in fresh water so as in high salt content water (sea water, brackish water).
- Resistant to chemicals, solvents, fuels and oils.
- Controlled swelling – minimise the risk of damage to concrete.
- Does not form foam or gas with water – durable seal as no air bubbles can breakdown and allow leaks.
- Outstanding chemical resistance.
- Reversible swelling process.
- Resistant to micro-organisms formation.
- Can seal joints with up to 5 bars water pressure.

### APPLICATION PROCEDURE

#### Surface preparation:

Joint surfaces must be structurally sound, clean and free from oil, grease and other contaminants. Carefully remove all loose particles and dust.

All substrate coatings, defective renders, formwork treatments and other previously applied materials that may affect the bond adversely should be removed. Clear any standing water on the surface.

Repair any concrete damages with a suitable MasterEma-co cementitious repair mortar. Plug active leaks with MasterSeal 590. Clear any standing water on the surface. The temperature during installation should be over +5°C and below +35°C.

#### Installation:

MasterSeal 910 has to be fully bonded to the prepared base using the hydroswelling paste MasterSeal 912. Other rigid adhesives might limit the expansion of the MasterSeal 910. Apply the gun grade hydroswelling paste MasterSeal 912 along a strip where MasterSeal 910 will be installed and to a width slightly larger than waterbar.

# MasterSeal 910

Formerly: Masterflex 610

**Hydroswelling waterbar for construction joints.**

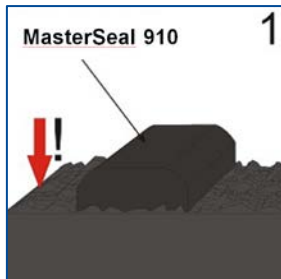

For normal joints width of 200-400 mm, place the waterbar along the middle of the joint. On wide joint surfaces (greater than 100 cm), two parallel waterbars may be laid for added safety.

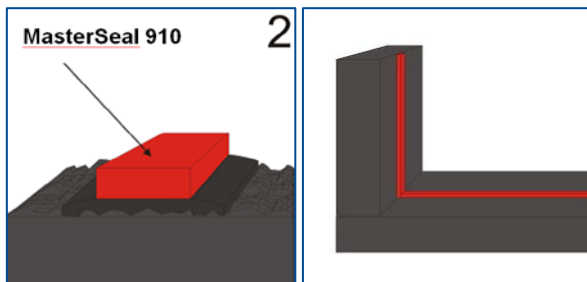

It is important to leave the minimum coverage from both the edges of concrete to provide sufficient concrete cover to absorb the swelling stresses.

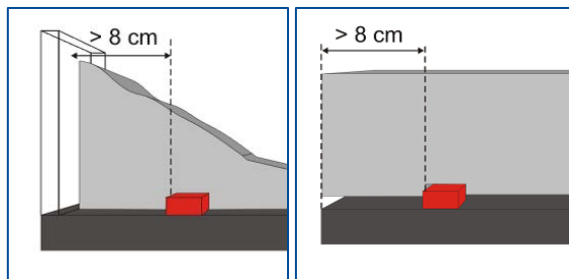

## PACKAGING

MasterSeal 910 is available in:

- 20 x 10mm ( $\pm$  5%) – 10 metre rolls
- 3 rolls (30 linear metres) per carton

## WATCH POINTS

Do not butt the joints of MasterSeal 910. Always lay the waterbar with a 5 cm overlap at the ends. Protect MasterSeal 910 and the joints after installation from dirt, sand, stones, rain, water and other liquids.

## CONTACT DETAILS

BASF plc,  
Construction Chemicals,  
P.O. Box 4,  
Earl Road,  
Cheadle,  
Cheshire, SK8 6QG  
Tel: +44 (0) 161 488 5264  
Fax +44 (0) 161 488 5220  
[www.master-builders-solutions.basf.co.uk](http://www.master-builders-solutions.basf.co.uk)

# MasterSeal 910

Formerly: Masterflex 610

Hydroswellung waterbar for construction joints.

## TYPICAL VOLUME EXPANTION OF MASTERSEAL 910

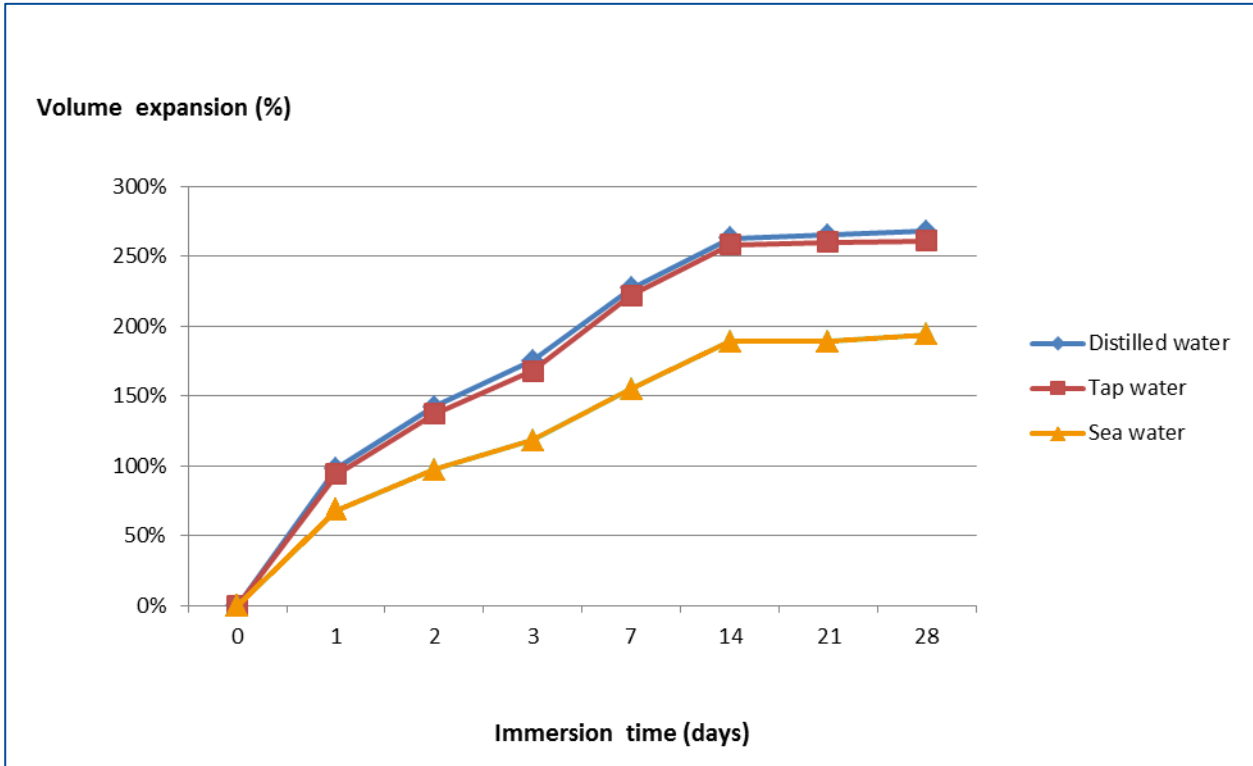

# MasterSeal 910

Formerly: Masterflex 610

**Hydroswellung waterbar for construction joints.**

Product Data	
Colour:	Red
Application temperature (substrate and material):	5°C to 35°C
Service life temperature:	-30°C to 35°C
Water pressure resistance:	5 Bar
Volume expansion:	See graph below
Logistics	
Shelf life:	12 months if stored according to manufacturer's instructions in unopened container.
Storage conditions:	Store in original sealed containers and at temperatures between 5°C and 30°C. Store under cover, off the ground, out of direct sunlight and protect from extremes of temperature. Protect the materials from all sources of moisture. Failure to comply with the recommended storage conditions may result in premature deterioration of the product or packaging.
Handling and transportation:	Refer to MasterSeal 910 Safety Data Sheet
Disposal:	Refer to MasterSeal 910 Safety Data Sheet

MasterSeal 910, BASF plc, Construction Chemicals, Version 1

**Health and Safety**

\*For full information on Health and Safety matters regarding this product the relevant Health and Safety Data Sheet should be consulted.

The following general comments apply to all products.

As with all chemical products, care should be taken during use and storage to avoid contact with eyes, mouth, skin and foodstuffs, (which may also be tainted with vapour until the product is fully cured and dried). Treat splashes to eyes and skin immediately. If accidentally ingested, seek medical attention. Keep away from children and animals. Reseal containers after use.

**Spillage**

Chemical products can cause damage; clean spillage immediately.

**DISCLAIMER**

"BASF plc, Construction Chemicals" (the Company) endeavours to ensure that advice and information given in Product Data Sheets, Method Statements and Material Safety Data Sheets (all known as Product Literature) is accurate and correct. However, the Company has no control over the selection of its products for particular applications. It is important that any prospective customer, user or specifier, satisfies him/her-self that the product is suitable for the specific application. In this process, due regard should be taken of the nature and composition of the background/base and the ambient conditions both at the time of laying/applying/installing the material and when the completed work is to be brought into use.

Accordingly, no liability will be accepted by the Company for the selection, by others, of a product, which is inappropriate to a particular application.

Products are sold subject to the Company's standard conditions of sale and all customers, users and specifiers, should ensure that they examine the Company's latest Product Literature.